

**Cabin Slim Thermal Energy System BC-e light: consists of protective housing and built-in equipment with gas condensing boiler TopGas® max (50 - 150)**

*Cabin Slim protective housing*

Protective housing with boilers in cascade connection suitable for outdoor installation.

- Each module consists of 1, 2 or 3 boilers of equal heat output, and individual the modules can be combined up to a maximum of 4 modules, or 8 boilers.
- Free standing impermeable module construction, with IPX5D electrical protection IP-X5D, contains front access door, it is made of coated steel epoxy powder RAL 9016, internal sides are insulated with an 8 mm thick mineral wool upholstery with aluminum foil. Contains ventilation grilles on the door adapted for usage of methane and LPG. There is no insulation on the door.
- Roof is made of steel, coated with epoxy powder RAL 9016 which guarantees perfect impermeability of the structure.

*Thermal Energy System BC-e light Built-in equipment*

Wall-hanging gas condensing boiler

TopGas® max (50-150) CE-0085CS0419

In each module the following equipment is installed:

- **Master:** 2 Hoval TopGas® max boilers with output 50, 65, 100, 125 or 150 kW, or 3 Hoval TopGas® max boilers with output 100, 125 and 150 kW
- **Slave:** 1, 2 or 3 boilers Hoval TopGas® max with output of 100, 125 and 150 kW
- Flow manifold made of pipe DN 100, insulated.
- Return manifold made of pipe DN 100, insulated.
- Connection to each TopGas® boiler with standard Hoval connection sets with pumps:
  - AS 32-TG max/SPS-I 10 PM1
  - AS 32-TG max/SPS-I 12 PM1
  - AS 40-TG/SPS-I 12 PM1
  - AS 40 Stratos Maxo 30/0,5-14
- Hydraulic connections of the boiler flow and return line made of black painted steel pipes, PN6 flanges on the boiler side and external shut-off valves.
- Insulation of flow and return pipes with mineral wool and aluminum foil.
- Safety equipment according to EN 12828: safety line, pressure gauge with three-way valve, double thermostat, maximum and minimum pressure switch, calibrated safety valve.
- Expansion diaphragm pressure vessel **only for protection of each individual boiler**, volume depending on the performance of the installed boiler and the content of the heating medium. Drain from safety valve with built-in funnel and drain pipe outside housing.
- Natural gas supply pipe with filter with external shut-off valve.
- Indoor installation of power supply and signal cables for boilers.
- External terminal box with IP65 protection for boiler power supply and signal cables.
- Stainless steel chimney with one wall and waterproof clamp, ending about 0.25 m above the roof of the protective housing.
- With condensate neutralization

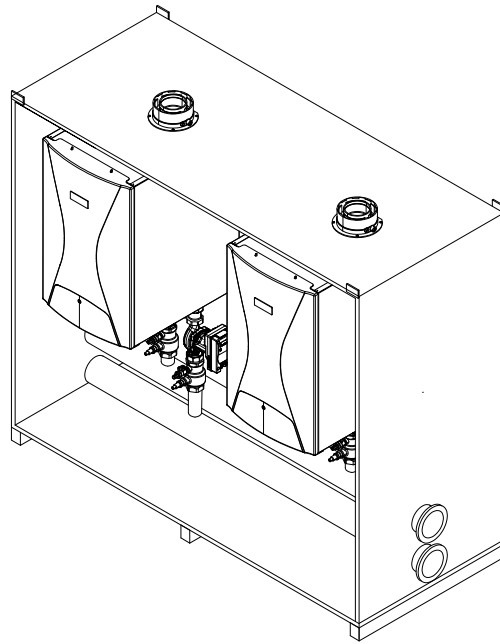

**Model range Master 2**

Modules with 2 boilers

- Slim BC-e light 2 100
- Slim BC-e light 2 130
- Slim BC-e light 2 200
- Slim BC-e light 2 250
- Slim BC-e light 2 300

**Model range Slave 1**

Modules with 1 boiler

- Slim BC-e Light 1 100
- Slim BC-e Light 1 125
- Slim BC-e Light 1 150

*Options*

- Indoor lighting and service socket
- Light for external signaling of the plant condition
- Circulation pump
- Heat exchanger
- Hydraulic switch

*Wall-hanging gas condensing boiler TopGas® max*

- With condensing boiler technology
- For the combustion of:
  - natural gas E
  - natural gas E with a hydrogen content (H2) of up to 20 % by vol.
  - propane according to DIN 51622
  - biomethane according to EN 16723
- Heat exchanger made of stainless steel
- Built-in:
  - water pressure guard for water shortage protection
  - flue gas temperature sensor with flue gas limiter function
  - automatic quick aspirator
  - Integrated backflow check valve on the combustion air side
  - Pre-mixing surface burner made of stainless steel
  - Modulating with gas/air group control

**Model range Master 2+**

Modules with 2 boilers and empty space

- Slim BC-e Light 2+ 200
- Slim BC-e Light 2+ 250
- Slim BC-e Light 2+ 300

**Model range Slave 1+**

Modules with 1 boiler and empty space

- Slim BC-e Light 1+ 100
- Slim BC-e Light 1+ 125
- Slim BC-e Light 1+ 150

**Model range Master 3**

Modules with 3 boilers

- Slim BC-e Light 3 300
- Slim BC-e Light 3 375
- Slim BC-e Light 3 450

- Automatic ignition
- Ionisation guard
- Minimum water flow necessary (see technical data)
- Wall-hanging gas condensing boiler fully clad with coated white steel plates

*Basic boiler control panel*

- Automatic function device with monitoring unit
- Modulating burner control
- Operation and fault indication

*Option*

- Propane
- Free-standing calorifier

*Delivery*

- Wall-hanging gas condensing boiler fully clad with fastening material for wall installation

**TopGas® max M**

with integrated automatic function device  
LMS14 including control panel

**Control panel**

- Digital screen display
- Pushbuttons and rotary knob for operation
- Fault signalling lamp
- Information display

**Control functions**

- Control functions integrated for
  - 1 heating/cooling circuit without mixer
  - 1 hot water charging circuit

**Operating mode selection**

- Heating curve setting
- Hot water temperature setting
- Day programs/week programs
- Frost protection function
- Display of fault messages
- Error acknowledgement key
- Chimney sweep function key (safety temperature limiter test)

**Options for controller**

- Can be expanded with:
  - Room control unit
  - Cascade module
- Can be networked with up to 8 automatic function devices in total

**Delivery**

- The boiler and installation come preassembled, built into the housing and ready for installation.

**On installation site**

- Mounting the module at the installation site
- Connection to the heating system, gas and power supply

**Master module**

Leading module with two or three TopGas® max wall-mounted gas condensing boilers in a protective housing for outdoor installation  
Built-in equipment in the master module:

- two or three TopGas® max wall-mounted gas condensing boilers
- Connection sets with pump and safety equipment for each boiler
- Expansion vessels for each boiler
- Gas valves with thermal protection for each boiler
- Chimney for each boiler
- Condensate neutralization box
- Insulated flow and return manifold with flanges
- Inside gas installation with main gas valve outside the housing
- Safety pressure switches for maximum and minimum pressure of heating water
- Safety thermostat for maximum temperature of heating water
- Heating cable with thermostat
- Outdoor temperature sensor
- Flow temperature sensor

**Delivery**

- The boiler and installation come preassembled, built into the housing and ready for installation.

**On installation site**

- Mounting the module at the installation site
- Connection to the heating system, gas and power supply

**Slave module**

Sequential module with one, two or three TopGas® max wall-mounted gas condensing boilers in a protective housing for outdoor installation

Built-in equipment in the slave module:

- Connection sets with pump and safety equipment for each boiler
- Expansion vessels for each boiler
- Gas valves with thermal protection for each boiler
- Chimney for each boiler
- Condensate neutralization box
- Insulated flow and return manifold with flanges
- Inside gas installation with main gas valve outside the housing
- Heating cable

**Delivery**

- The boiler and installation come preassembled, built into the housing and ready for installation.

**On installation site**

- Mounting the module at the installation site
- Connection to the heating system, gas and power supply

**Slave** modules are intended as an add-on to **master** modules

**Slave** modules do **not include** pressure switches, safety thermostat, electric heating cable thermostat.

**Cabin Slim Thermal Energy System BC-e light:** consists of protective housing and built-in equipment with gas condensing boiler TopGas® max (50 - 150)

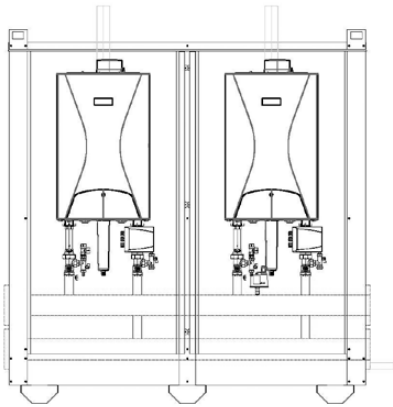

**Master** modules work independently and can be expanded with **slave** modules. Installed in **master** modules are pressure switches, safety thermostat, thermostat for electric heating cables.

**Cabin Slim Thermal Energy System BC-e light - TopGas® max master**

Cabin Slim Thermal Energy System BC-e light - TopGas® max wall-mounted gas condensing boilers consists of protective housing and other built-in equipment for outdoor installation.

- Integrated regulation functions:
  - heating circuit
  - cascade control
- Can be connected with up to 8 controller modules in separate housing for control of heating circuits (optional)

Stainless steel heat exchanger with modulating stainless steel burner and automatic function device LMS14 and control panel fully clad. Connection set with pump, safety equipment and hydraulic switch.

**Delivery**

- The boilers and installation delivered preassembled in housing, ready for installation.

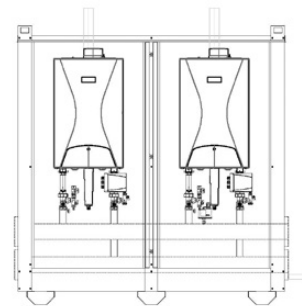

**Master module with 2 boilers**

Cabin Slim Thermal Energy System BC-e light with TopGas® max	Nominal heat load at 50/30 °C kW <sup>1)</sup>
100	9.1-99.8
130	14.9-139.8
200	22.3-204.0
250	26.3-250.6
300	29.8-300.8

<sup>1)</sup> kW = modulation range

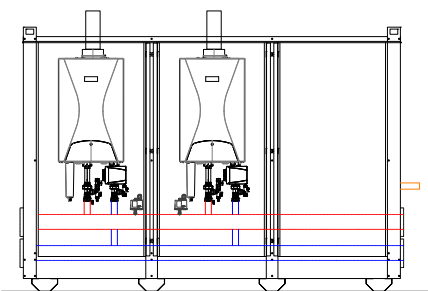

**Master module with 2 boilers and empty space**

Cabin Slim Thermal Energy System BC-e light with TopGas® max	Nominal heat load at 50/30 °C kW <sup>1)</sup>
200	22.3-204.0
250	26.3-250.6
300	29.8-300.8

<sup>1)</sup> kW = modulation range

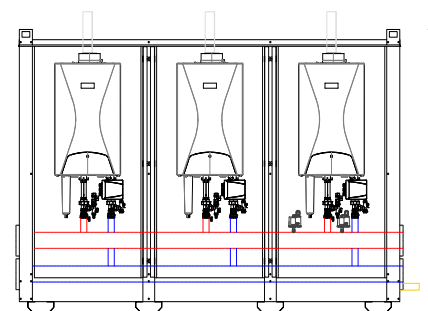

**Master module with 3 boilers**

Cabin Slim Thermal Energy System BC-e light with TopGas® max	Nominal heat load at 50/30 °C kW <sup>1)</sup>
300	22.3-306.0
375	26.3-375.9
450	29.8-451.2

<sup>1)</sup> kW = modulation range

**Part Nr.**

- CSL2T 7019 687 HR
- CSL2T 7019 688 HR
- CSL2T 7019 689 HR
- CSL2T 7019 690 HR
- CSL2T 7019 691 HR

- CSLX2T 7019 689 HR
- CSLX2T 7019 690 HR
- CSLX2T 7019 691 HR

- CSL3T 7019 689 HR
- CSL3T 7019 690 HR
- CSL3T 7019 691HR

Cabin Slim Thermal Energy System BC-e light: consists of protective housing and built-in equipment with gas condensing boiler TopGas® max (50 - 150)

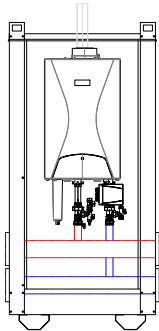

**Slave** modules are intended as an add-on to **master** modules

**Slave** modules do **not include** pressure switches, safety thermostat, electric heating cable thermostat or control module TTE-BM

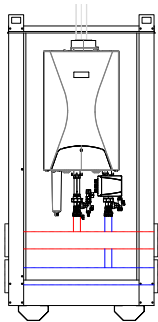

**Cabin Slim Thermal Energy System BC-e light - TopGas® max slave**

Cabin Slim Thermal Energy System BC-e light - TopGas® max wall-mounted gas condensing boilers consists of protective housing and other built-in equipment for outdoor installation, as an expansion for **master** cabin.

- Integrated regulation functions:
  - heating circuit
  - cascade control
- Can be connected with up to 8 controller modules in separate housing for control of heating circuits (optional)

Stainless steel heat exchanger with modulating stainless steel burner and automatic function device LMS14 and control panel fully clad. Connection set with pump, safety equipment and hydraulic switch.

*Delivery*

- The boilers and installation delivered preassembled in housing, ready for installation.

**Slave module with 1 boiler**

Cabin Slim Thermal Energy System BC-e light with TopGas® max	Nominal heat load at 50/30 °C kW <sup>1)</sup>
--	--

100	22.3-102.0
125	26.3-125.3
150	29.8-150.4

<sup>1)</sup> kW = modulation range

**Part Nr.**

CSLEXT 7019 689 HR  
 CSLEXT 7019 690 HR  
 CSLEXT 7019 691 HR

**Cabin Slim Thermal Energy System BC-e light:** consists of protective housing and built-in equipment with gas condensing boiler TopGas® max (50 - 150)

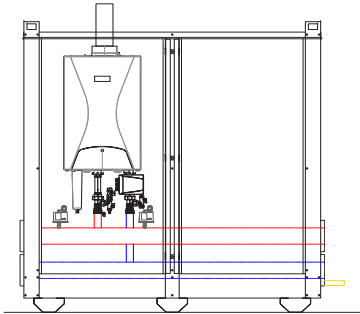

**Slave** modules are intended as an add-on to **master** modules  
**Slave** modules do **not include** pressure switches, safety thermostat, electric heating cable thermostat and control module TTE-BM

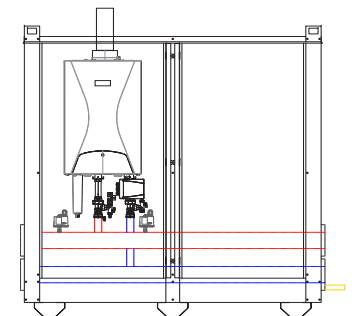

**Cabin Slim Thermal Energy System BC-e light - TopGas® max slave**

Cabin Slim Thermal Energy System BC-e light - TopGas® max all-mounted gas condensing boilers consists of protective housing and other built-in equipment for outdoor installation, as an expansion for **master** cabin.

- Integrated regulation functions:
  - heating circuit
  - cascade control
- Can be connected with up to 8 controller modules in separate housing for control of heating circuits (optional)

Stainless steel heat exchanger with modulating stainless steel burner and automatic function device LMS14 and control panel fully clad. Connection set with pump, safety equipment and hydraulic switch.

**Delivery**

- The boilers and installation delivered preassembled in housing, ready for installation.

**Slave module with 1 boiler and empty space**

Cabin Slim Thermal Energy System BC-e light with TopGas® max	Nominal heat load at 50/30 °C kW <sup>1)</sup>
100	22.3-102.0
125	26.3-125.3
150	29.8-150.4

<sup>1)</sup> kW = modulation range

Modbus module OCI351  
**For connecting TopGas max boiler to the Top-Tronic® E regulation**



2085 886

Preparation for Glycol inside Cabin (price per boiler)

GLYCOLTG001HR

**Slave module - empty**  
 Empty housing for placement of heat exchanger or hydraulic switch.

on demand

**Plate heat exchanger**  
 for installation in the empty space in the cabin module. For selection and technical characteristics contact Hoval support service.

on demand



**Hydraulic switch**  
 for installation in the empty space in the cabin module. For selection and technical characteristics contact Hoval support service.

on demand

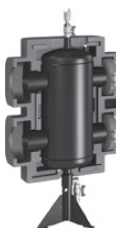

<b>Cabin Slim Thermal Energy System BC-e light - TopGas® max 100-300 master 2</b>		<b>100</b>	<b>130</b>	<b>200</b>	<b>250</b>	<b>300</b>	
<b>Number of boilers in cabin</b>		<b>2</b>	<b>2</b>	<b>2</b>	<b>2</b>	<b>2</b>	
• Nominal heat output at (natural gas)	50/30°	kW	9.1-99.8	14.9-139.8	22.3-204.0	26.3-250.6	29.8-300.8
	80/60°	kW	7.8-91.8	13.0-132.8	19.4-188.2	22.5-227.8	25.7-276.6
	Nominal load with natural gas	kW	8.2-94.2	13.5-136.2	20.1-193.4	24.2-232	26.6-281.6
• Max. operating pressure heating	bar	3.0	4.5	6.0	6.0	6.0	
• Gas connection (on boiler)	inch	R ¾"	R ¾"	R 1"	R 1"	R 1"	
• Flue gas/combustion air connection (on boiler)	mm	80 / 125	80 / 125	100 / 150	100 / 150	100 / 150	
• Gas flow pressure min./max	Natural gas E/LL	mbar	18-50	18-50	18-50	18-50	18-50
	Propane	mbar	37-50	37-50	37-50	37-50	37-50
• Gas connection values at 15 °C/1013 mbar	Natural gas E (W <sub>0</sub> = 15,0 kWh/m <sup>3</sup> ) (NCV = 9,97 kWh/m <sup>3</sup> )	m <sup>3</sup> /h	0.8-9.8	1.4-14.0	2.1-20.0	2.5-24.0	2.7-29.0
	Propane (NCV = 25,9 kWh/m <sup>3</sup> )	m <sup>3</sup> /h	0.3-3.8	0.6-5.6	0.8-8.0	1.3-9.6	1.1-11.6
	Operation voltage	Volt/Hz	1 ~ 230/50	1 ~ 230/50	1 ~ 230/50	1 ~ 230/50	1 ~ 230/50
• Electrical power consumption min./max. (for 2 boilers)	Watt	16/150	22/230	33/278	35/452	27/594	
• Electrical power consumption max. (for 2 pumps)	Watt	640	640	640	640	680	
• Electrical power consumption min./max. (heating cable)	Watt	0 / 48	0 / 48	0 / 48	0 / 48	0 / 48	
• Safety valve release pressure	bar	3.0	3.0	3.0	3.0	3.0	
• Expansion vessel volume	liter	8.0	8.0	8.0	8.0	8.0	
• Boiler water content (V <sub>(H<sub>2</sub>O)</sub> ) - single boiler	liter	3.0	4.5.0	6.5	8.0	9.5	
• Gas valve with thermal release	inch	¾"	¾"	1"	1"	1"	
• Hoval connection set with pump		AS 32-TG max/SPS-I 10 PM1	AS 32-TG max/SPS-I 12 PM1	AS 40-TG/ SPS-I 12 PM1	AS 40-TG/ SPS-I 12 PM1	AS 40 Stratos Maxo 30/0,5- 14	
• Boiler weight (for 2 boilers)	kg	84	106	112	148	178	
• Cabin weight	kg	465	465	465	465	465	
• Cabin + built-in equipment total weight	kg	593	615	641	657	697	
• Condensate drain dimension	DN	40	40	40	40	40	
• Heating flow/return dimension	DN	100	100	100	100	100	
• Gas connection dimension	inch	1"	1"	1½"	1½"	1½"	
• Gas connection type		thread	thread	thread	thread	thread	

Values in the table are subject to change

Cabin Slim Thermal Energy System BC-e light - TopGas® max 300-450 master 3		300	375	450
Number of boilers in cabin		3	3	3
• Nominal heat output at (natural gas)				
50/30°	kW	22.3-306.0	26.3-375.9	29.8-451.2
80/60°	kW	19.4-282.3	22.5-341.7	25.7-414.9
Nominal load with natural gas	kW	20.1-290.1	24.2-348	26.6-422.4
• Max. operating pressure heating	bar	6.0	6.0	6.0
• Gas connection (on boiler)	inch	R 1"	R 1"	R 1"
• Flue gas/combustion air connection (on boiler)	mm	100 / 150	100 / 150	100 / 150
• Gas flow pressure min./max				
Natural gas E/LL	mbar	18-50	18-50	18-50
Propane	mbar	37-50	37-50	37-50
• Gas connection values at 15 °C/1013 mbar				
Natural gas E (W <sub>0</sub> = 15,0 kWh/m <sup>3</sup> ) (NCV = 9,97 kWh/m <sup>3</sup> )	m <sup>3</sup> /h	2.1-30.0	2.5-36.0	2.7-43.5
Propane (NCV = 25,9 kWh/m <sup>3</sup> )	m <sup>3</sup> /h	0.8-12.0	1.3-14.4	1.1-17.4
• Operation voltage	Volt/Hz	1 ~ 230/50	1 ~ 230/50	1 ~ 230/50
• Electrical power consumption min./max. (for 3 boilers)	Watt	33/417	35/678	27/891
• Electrical power consumption max. (for 3 pumps)	Watt	960	960	1020
• Electrical power consumption min./max. (heating cable)	Watt	0 / 48	0 / 48	0 / 48
• Safety valve release pressure	bar	3.0	3.0	3.0
• Expansion vessel volume	liter	8.0	8.0	8.0
• Boiler water content (V <sub>(H<sub>2</sub>O)</sub> ) - single boiler	liter	6.5	8.0	9.5
• Gas valve with thermal release	inch	1"	1"	1"
• Hoval connection set with pump		AS40-TG max SPS-I 12	AS40-TG max SPS-I 12	AS40-TG max MAXO 30/0,5- 14
• Boiler weight (for 3 boilers)	kg	198	222	267
• Cabin weight	kg	620	620	620
• Cabin + built-in equipment total weight	kg	881	905	962
• Condensate drain dimension	DN	40	40	40
• Heating flow/return dimension	DN	100	100	100
• Gas connection dimension	inch	1 1/2"	2"	2"
• Gas connection type		thread	thread	thread

Values in the table are subject to change

Cabin Slim Thermal Energy System BC-e light - TopGas® max 100-150 slave		100	125	150
Number of boilers in cabin		1	1	1
• Nominal heat output at (natural gas)				
50/30°	kW	22.3-102.0	26.3-125.3	29.8-150.4
80/60°	kW	19.4-94.1	22.5-113.9	25.7-138.3
Nominal load with natural gas	kW	20.1-96.7	24.2-116	26.6-140.8
• Max. operating pressure heating	bar	6.0	6.0	6.0
• Gas connection (on boiler)	inch	R 1"	R 1"	R 1"
• Flue gas/combustion air connection (on boiler)	mm	100 / 150	100 / 150	100 / 150
• Gas flow pressure min./max				
Natural gas E/LL	mbar	18-50	18-50	18-50
Propane	mbar	37-50	37-50	37-50
• Gas connection values at 15 °C/1013 mbar				
Natural gas E (W <sub>0</sub> = 15,0 kWh/m <sup>3</sup> ) (NCV = 9,97 kWh/m <sup>3</sup> )	m <sup>3</sup> /h	2.1-10.0	2.5-12.0	2.7-14.5
Propane (NCV = 25,9 kWh/m <sup>3</sup> )	m <sup>3</sup> /h	0.8-4.0	1.3-4.8	1.1-5.8
• Operation voltage	Volt/Hz	1 ~ 230/50	1 ~ 230/50	1 ~ 230/50
• Electrical power consumption min./max. (boiler)	Watt	33/139	35/226	27/297
• Electrical power consumption max. (pump)	Watt	320	320	340
• Electrical power consumption min./max. (heating cable)	Watt	0 / 48	0 / 48	0 / 96
• Safety valve release pressure	bar	3.0	3.0	3.0
• Expansion vessel volume	liter	8.0	8.0	8.0
• Boiler water content (V <sub>(H<sub>2</sub>O)</sub> ) - single boiler	liter	6.5	8.0	9.5
• Gas valve with thermal release	inch	1"	1"	1"
• Hoval connection set with pump		AS40-TG max SPS-I 12	AS40-TG max SPS-I 12	AS40-TG max MAXO 30/0,5-14
• Boiler weight	kg	66	74	89
• Cabin weight	kg	240	240	240
• Cabin + built-in equipment total weight	kg	332	340	360
• Condensate drain dimension	DN	40	40	40
• Heating flow/return dimension	DN	100	100	100
• Gas connection dimension	inch	1"	1"	1"
• Gas connection type		thread	thread	thread

Values in the table are subject to change

**Cabin Slim Thermal Energy System BC-e light  
- TopGas® max**  
(Dimensions in mm)

Cabin for single boiler

**Notice:**  
Dimensions are approximate and can be subject to changes and adjustments.

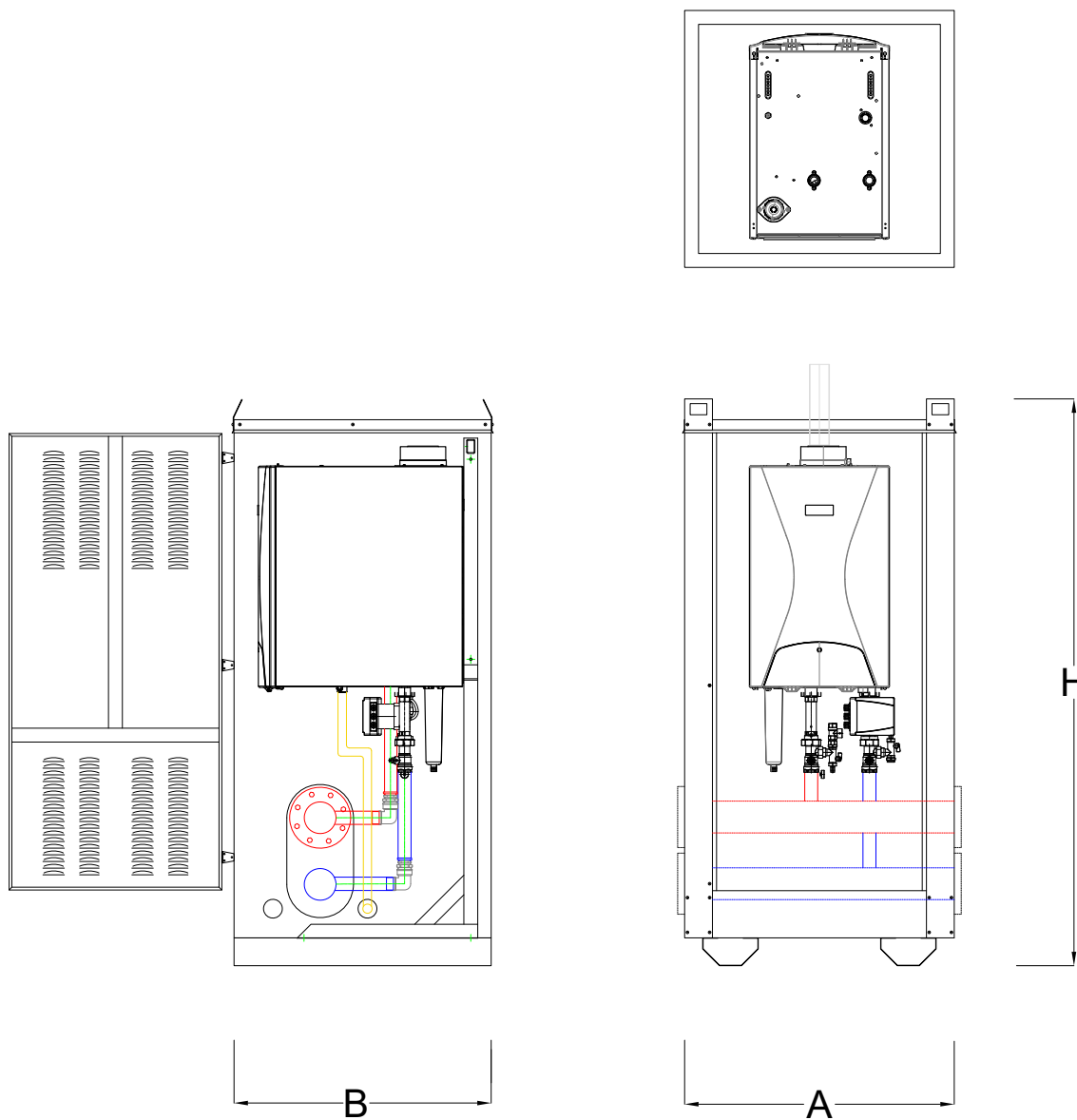

CabinSlim Type/places	B	A	H
Single	855	970	2040

**Notice:**  
For weights check technical data

**Cabin Slim Thermal Energy System BC-e light  
- TopGas® max**  
(Dimensions in mm)

Cabin for 2 boilers

**Notice:**  
Dimensions are approximate and can be subject to changes and adjustments.

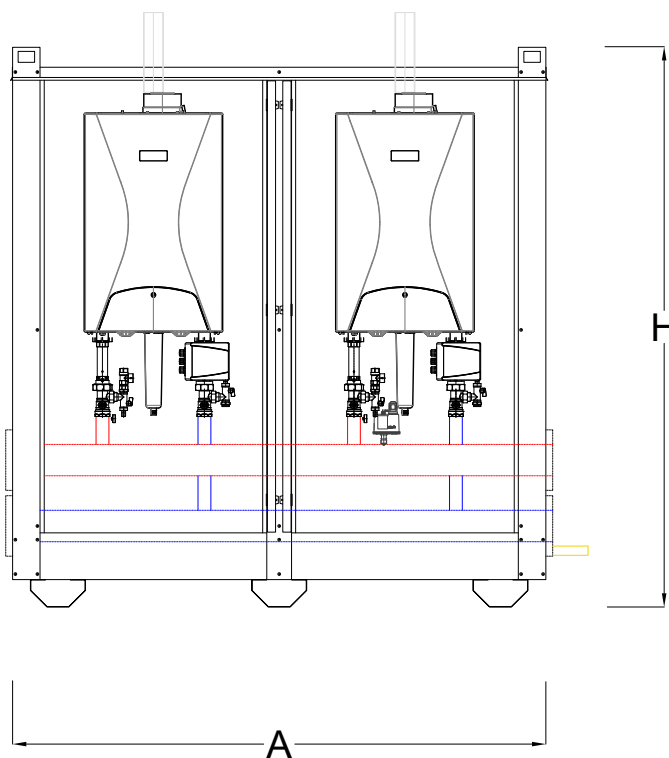
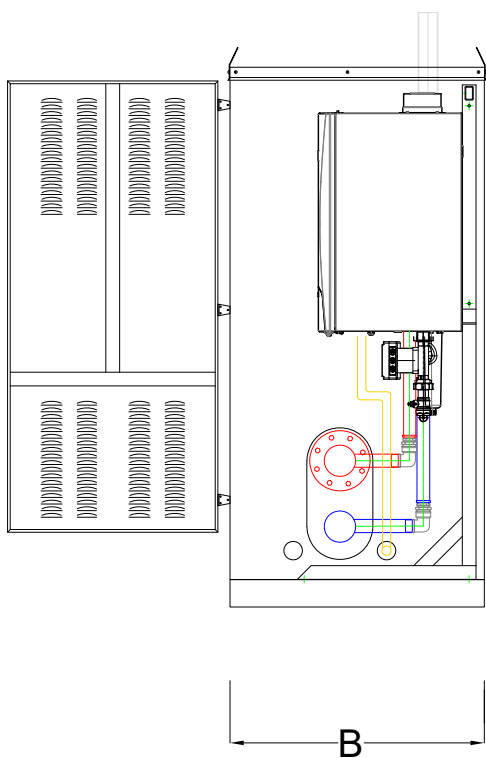
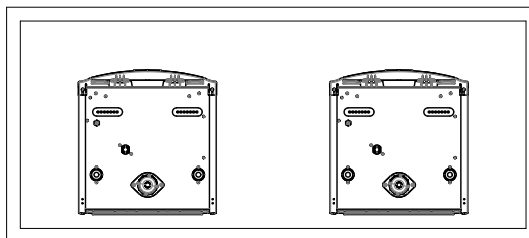

CabinSlim Type/places	B	A	H
Double	855	1940	2040

**Notice:**  
For weights check technical data

**Cabin Slim Thermal Energy System BC-e light**

**- TopGas® max**

(Dimensions in mm)

Cabin for 3 boilers

**Notice:**  
Dimensions are approximate and can be subject to changes and adjustments.

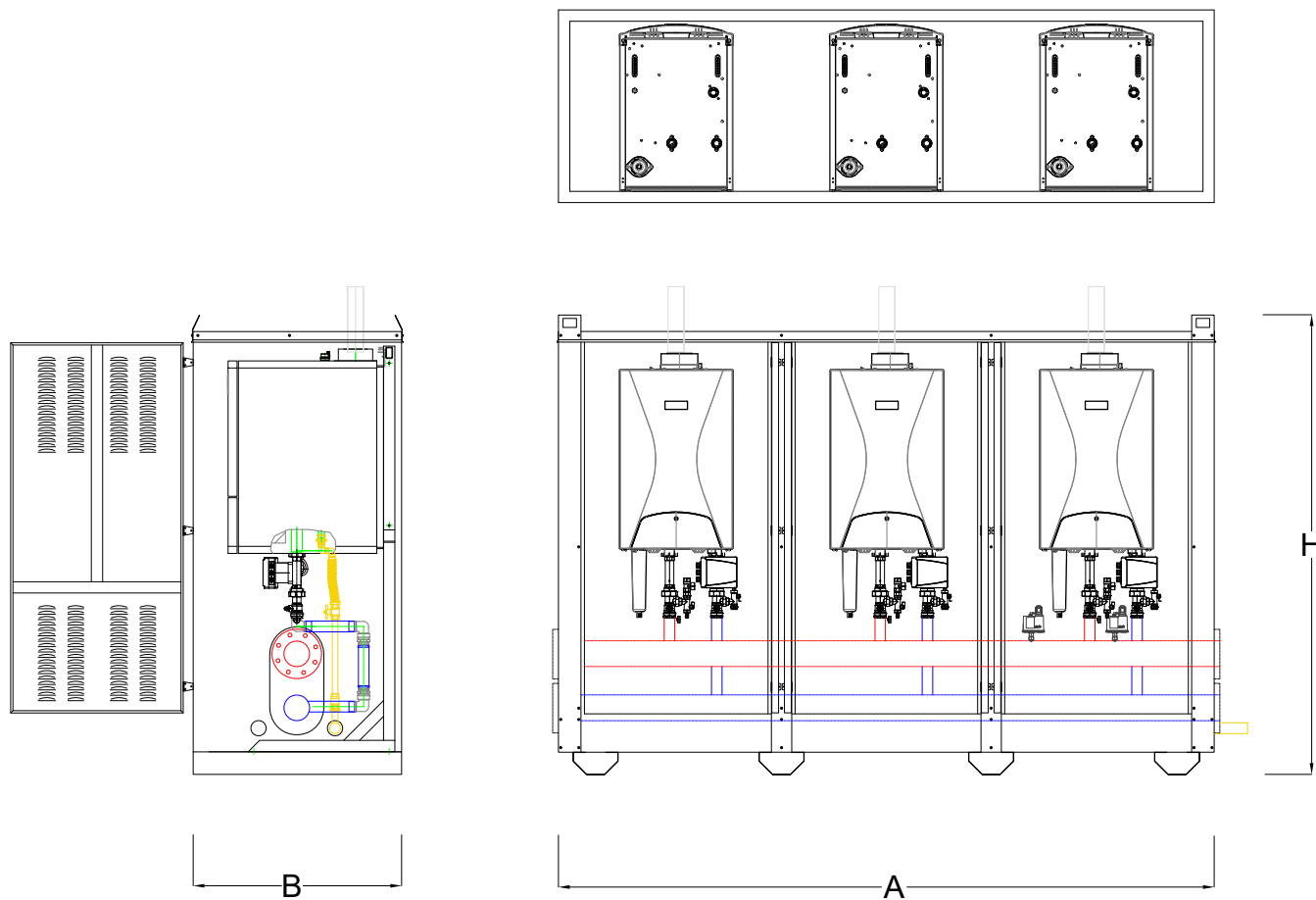

CabinSlim Type/places	B	A	H
Triple	855	2910	2040

**Notice:**  
For weights check technical data

Cabin Slim Thermal Energy System BC-e light  
- TopGas® max

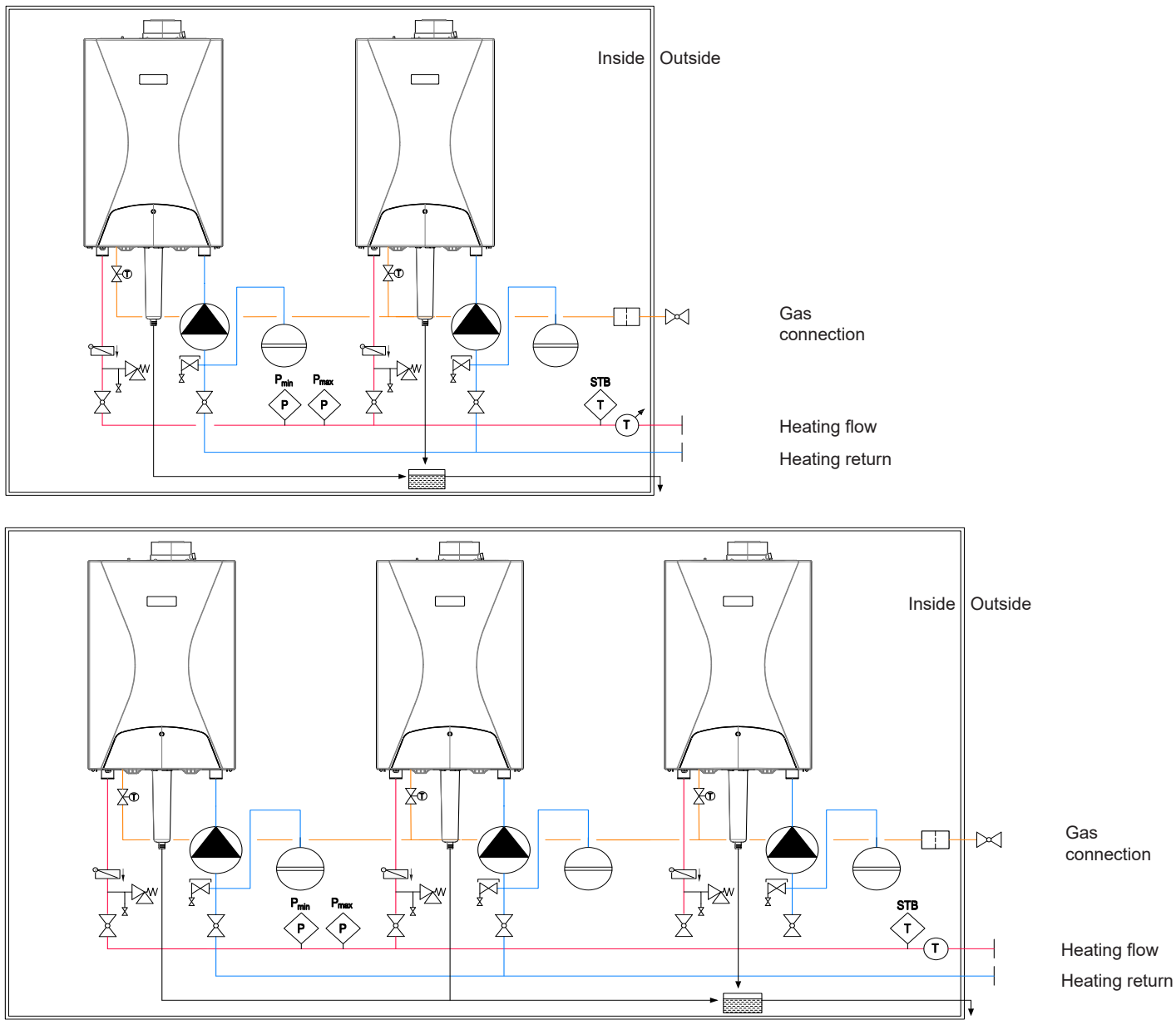

- Manometer
- Thermometer
- Safety valve
- Thermally releasing gas valve
- Gas filter
- STB Safety thermostat
- $P_{min}$  Minimum water pressure switch
- $P_{max}$  Maximum water pressure switch

Safety equipment according to EN 12828 norm

## Standards and guidelines

The following standards and guidelines must be complied with:

- Hoval technical information and installation instructions
- hydraulic and technical control regulations of Hoval
- local building law
- fire protection regulations
- DIN EN 12828  
Safety-relevant requirements
- DIN EN 12831 Heaters  
Rules for the calculation of the heat requirements of buildings
- VDI 2035 Protection against damage by corrosion and boiler scale formation in heating and service water installations
- local fire brigade regulations

## Water quality

### Filling and replacement water, heating water

#### The following applies:

- VDI 2035
- In addition, the EN 14868 standard must be applied, as well as the manufacturer-specific specifications

### Manufacturer-specific specifications

#### Filling and replacement water

The filling and replacement water must be fully demineralised.

#### Heating water

- In the case of full demineralisation of the filling and replacement water, the electrical conductivity of the heating water must not exceed the value of 100 µS/cm.
- pH value of the heating water for systems with aluminium alloy as water-side material 8.0 to 8.5 (measurement 10 weeks after commissioning at the earliest)
- The sum of the chloride, nitrate and sulphate contents in the heating water must not exceed 50 mg/l in total.

#### Additional notices

- Hoval boilers and calorifiers are suitable for heating systems without significant oxygen intake. (System type I according to EN 14868).
- The following systems must be equipped with separate circuits:
  - Systems operated with softened water.
  - Plants with continual oxygen intake (e.g. underfloor heating without diffusion-proof plastic piping) or intermittent oxygen intake (e.g. requiring frequent topping-up).
- In the case of bivalent heating systems, the values of the heat generator with the strictest requirement for water quality must be complied with.
- If only the boiler is replaced in an existing plant, it is not recommended for the entire heating system to be refilled, provided that the heating water already contained in the system complies with the relevant directives or standards.
- Before filling new systems and, where necessary, existing heating systems containing

heating water that does not comply with the directives or standards, the heating system must be professionally cleaned and flushed. The boiler must not be filled until the heating system has been flushed.

## Frost protection agent

Boiler must not be filled with frost protection agent. In systems with frost protection agent boiler must be hydraulically separated from system.

- see separate engineering sheet "Use of frost protection agent".
- Monopropylene glycol should be used as the antifreeze (e.g., Sentinel X500; Fernox Alpha 11). The proportion should be between 20% and a maximum of 30%.

## Cabin

Halogen compounds cannot be placed in the cabin of the thermal module and there must not be the possibility of entry of the contaminated air in the cabin (e.g. from wash-, dryer-, work room, hairdressers and so on)

Halogen compounds can be caused by cleaning and degreasing solutions, dissolvents, glue and bleaching lyes.

## Combustion air supply

Combustion air is supplied via ventilation grille located on the front doors of the cabin.

The cabin must be positioned so the air intake through the grilles is unobstructed.

There must be no possibility to close the air supply opening. For direct combustion air to boiler (LAS system) mount the connection for direct combustion air inlet.

The minimum free cross-section for the combustion air can be assumed simplified as follows. Considering nominal output!

- **Room air-dependent operation:**  
Minimum free cross-section of the opening into the open: 150 cm<sup>2</sup> or twice 75 cm<sup>2</sup> and additionally 2 cm<sup>2</sup> necessary for each kW of output over 50 kW for vent in to the open.
- **Room air-independent operation with separate combustion air pipe to the boiler:**  
0.8 cm<sup>2</sup> per 1 kW of output. The pressure drop in the combustion air pipe must be considered for the calculation of the flue gas system  
Cabin Slim BC-e light has grilles for combustion air supply on the plating. They must be secured from blockage (e.g. from dirt, ice, snow...).

## Gas connection

### Commissioning

- Start-up is to be carried out only by a specialist.
- Burner setting values according to the installation instructions.

### Manual gas shut-off valve and gas filter

Immediately in front of the boiler, a manual gas shut-off device (valve) is installed, according to relevant regulations. An approved gas filter is also installed in the gas supply pipe between the gas valve and the boiler in order to prevent malfunction due to foreign particles being carried along with the gas.

**Type of gas**

- The boiler is only to be operated with the type of gas stated on the rating plate.
- A gas pressure controller to reduce the boiler inlet pressure must be installed on site for propane.

**Gas pressure natural gas**

- In the boilers with heat output above 70 kW, install gas pressure regulator in gas supply, according to the EN88-1.

Necessary flow pressure at the boiler inlet:  
min. 17.4 mbar, max. 50 mbar

**Gas pressure propane**

- install gas pressure regulator in gas supply when using propane

Necessary flow pressure at the boiler inlet:  
min. 37 mbar, max. 50 mbar

**Dirt separator**

It is recommended to install a dirt separator in the return before Cabin Slim Thermal Energy System.

**Pump after-run time**

- The circulating pump must continue to run for at least 2 minutes each time the burner is switched off (the pump after-run time is included in the boiler control with the TopTronic® E regulation).

**Minimum water circulation**

- Depending on the type of the boiler there is different required water circulation. See technical data.
- When the burner is running so must the circulation pump so the minimum water circulation is provided.

**Condensate drain**

- The condensate from the flue gas system can be discharged through the boiler. A condensate trap is not needed anymore with the flue gas system.
- The condensate drainage without neutralization is allowed, if you are using for the drain only plastic tubes or stoneware (possibly obtain special exemption from the relevant authority).
- A siphon is installed at the condensate outlet on the gas boiler (included in the boiler scope of delivery).
- The condensate must be openly lead into the sewer (funnel).

**Flue gas system**

- A flue gas temperature limiter is integrated into the boiler.
- Cabin Slim Thermal Energy System BC-e light is supplied with flue gas line with height of cca. 250 mm above the Cabin Slim Thermal Energy System roof. If necessary it can be connected to external chimney. Gas boilers must be connected to a certified and approved flue gas system such as flue gas lines.
- Flue gas lines must be gas-, condensate- and overpressure-tight.
- The flue gas lines must be secured against unwanted loosening of the plug connections.
- The flue gas system must be connected with an angle, so that the resulting condensate of the flue gas system can flow back to the boiler and can be neutralized there before discharging into the sewer.
- Gas boilers with condensation heat utilisation are to be connected to a flue gas line min. temperature class T120

**Expansion tank**

- An adequately dimensioned pressure expansion tank for the whole system must be provided.
- Cabin Slim Thermal Energy System BC-e light is equipped with pressure expansion tank dimensioned **only** for protection of Cabin Slim Thermal Energy System.
- At temperatures above 70 °C pre-expansion vessel must be installed.

**Noise level**

- The sound **power** level value is independent on local and spacial circumstances.
- The sound **pressure** level is dependent on the installation conditions and can e.g. be 5 to 10 dB(A) lower than the sound power level at a distance of 1 m.